

**Part Number: PT938-89100**

**NOTE:** Part number of this accessory may not be the same as the part number shown.

**Kit Contents**

Item #	Quantity Reqd.	Description
1	1	LHS Board Assembly
2	1	RHS Board Assembly





**Vehicle Service Parts** (may be required for reassembly)

Item #	Quantity Reqd.	Description
1		
2		
3		

**Hardware Bag Contents**

Item #	Quantity Reqd.	Description
1	12	M8 x 25 Serrated Flange Screw
2	1	Instruction Sheet

**Legend**

	<b>STOP:</b> Damage to the vehicle may occur. Do not proceed until process has been complied with.
	<b>OPERATOR SAFETY:</b> Use caution to avoid risk of injury.
	<b>CAUTION:</b> A process that must be carefully observed in order to reduce the risk of damage to the accessory/vehicle and to ensure a quality installation.
	<b>TOOLS &amp; EQUIPMENT:</b> Used in Figures calls out the specific tools and equipment recommended for this process.
	<b>REVISION MARK:</b> This mark highlights a change in installation with respect to previous issue.

**Additional Items Required For Installation**

Item #	Quantity Reqd.	Description

**Conflicts**

--

**Recommended Tools**

<b>Personal &amp; Vehicle Protection</b>	<b>Notes</b>
None	
<b>Special Tools</b>	<b>Notes</b>
None	
<b>Installation Tools</b>	<b>Notes</b>
Ratchet	3/8"
Sockets	12 mm, 13 mm
Extension	3/8" - 3"
Torque Wrench	3/8" Drive (25 lbf-ft)
<b>Special Chemicals</b>	<b>Notes</b>
None	

**General Applicability**

--

**Recommended Sequence of Application**

Item #	Accessory
1	
2	
3	

\*Mandatory

Care must be taken when installing this accessory to ensure damage does not occur to the vehicle. The installation of this accessory should follow approved guidelines to ensure a quality installation.

These guidelines can be found in the "Accessory Installation Practices" document.

This document covers such items as:-

- Vehicle Protection (use of covers and blankets, cleaning chemicals, etc.).
- Safety (eye protection, rechecking torque procedure, etc.).
- Vehicle Disassembly/Reassembly (panel removal, part storage, etc.).
- Electrical Component Disassembly/Reassembly (battery disconnection, connector removal, etc.).

Please see your Toyota dealer for a copy of this document.

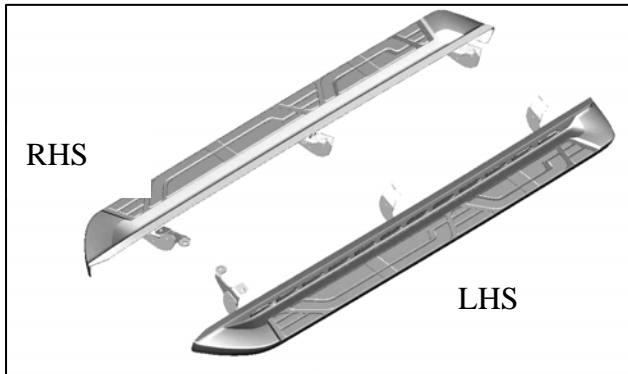

**1. Remove Running Board from Packaging.**

- (a) Remove left and right running board assemblies and a hardware bag from package and place on a clean protected work surface. Verify kit contents and inspect the running board for damage.

**2. Running Board Preparation**

**LH / RH Side**

- (a) Verify hardware bag content by referring to the cover page of this instruction sheet.
- (b) Using a 12mm socket, remove & discard twelve (12) OEM Hex bolts from all bracket positions (3 brackets per side) underneath the vehicle (6 bolts from each side).
- (c) Locate the center upper position 8mm factory-threaded nut. Install one bolt and hand fasten about 5 turns into the nut. (Fig. 2-1)

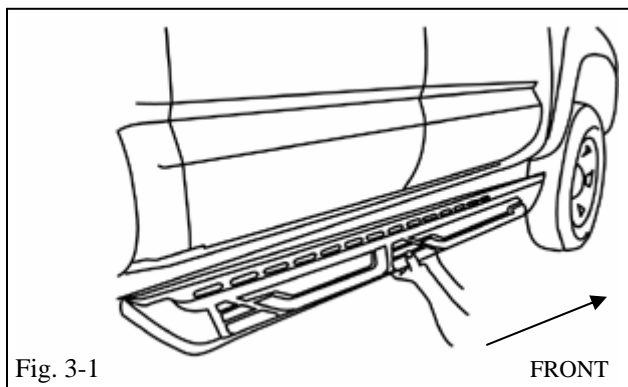
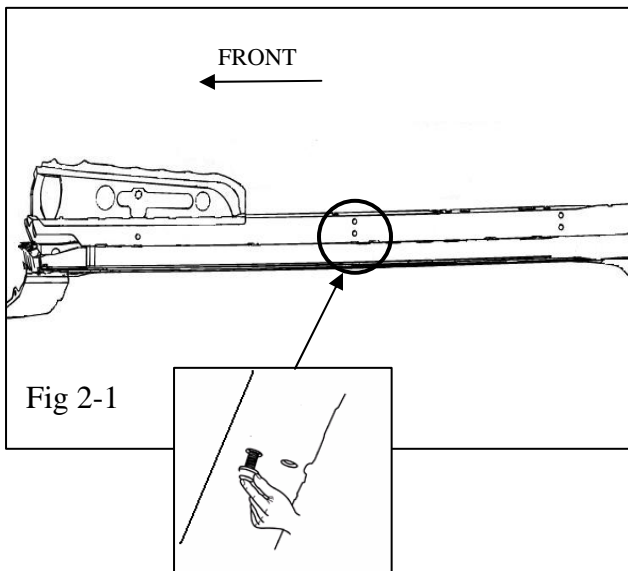

**3. Running Board Installation (RH Side).**

- (a) Lift right side running board assembly into position. (Fig. 3-1)
- (b) Engage slot of center bracket under head of bolt to secure position. (Fig. 3-2) Support

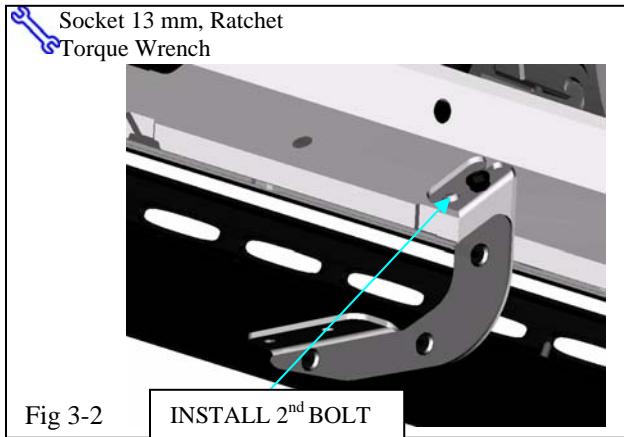

with hand while installing the second bolt a minimum of 5 turns.



- (c) Align the Bracket holes to the factory holes and install other M8 bolts at remaining locations to secure brackets. Hand Tighten all hardware. Torque all six bolts to 14.4 lbf-ft.

#### 4. Running Board Installation (LH Side).

- (a) Repeat step 3(a) to 3(e) for left hand side.

Checklist - these points **MUST** be checked to ensure a quality installation.

Check:

Look For:

Accessory Function Checks

Visual check of running board

  Inspect Running Board bolts to vehicle torque (M8 bolts)

Ensure Running Board is level and parallel to vehicle rocker.

Bracket to vehicle bolts must be within 10.8 to 18.0 lbf-ft.